

2.3 Tonne Power Swivel

KEY FEATURES & BENEFITS - MACH2077

Hydrostatic
TRANSMISSION



The Thwaites 2.3 Tonne Power Swivel, Stage V dumper is manufactured with contractors and hirers in mind – ensuring operator safety, reducing risk on site and improving performance. Powered by an 18.1 kW 3-cylinder Yanmar engine, delivering 107 Nm max torque for optimum traction and control, this machine is driven by a Hydrostatic transmission, making it simple and straightforward to operate.

This compact plus machine is available exclusively as a Power Swivel machine only, giving optimum performance when space is at a premium. The Power Swivel skip enables a 90° rotation left and right, allowing the machine easier access to tip loads in restricted areas, giving the operator greater control and reducing risk on site. It has a fully welded 6 mm steel plate skip to the mouth and sides with reinforced box section fitted to minimise skip damage.

Each dumper is supplied as standard with a Spring Activated Hydraulic Release (SAHR) Handbrake, full LED road lights including daylight running lights, ROPS frame, towing bracket, LED beacons and a reverse alarm.

Easy to service and maintain with market leading residuals.

Safe, compliant and competitive.

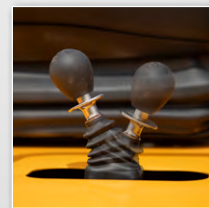

Snap this QR code
from your smart
phone for more
information



Thwaites

Thwaites Ltd, Leamington Spa,
Warwickshire, CV32 7NQ, England
Tel +44 (0)1926 422471

www.thwaitesdumpers.co.uk



GET THE JOB DONE.

2.3 Tonne Power Swivel

DIMENSIONS & SPECIFICATIONS - MACH2077

(mm)

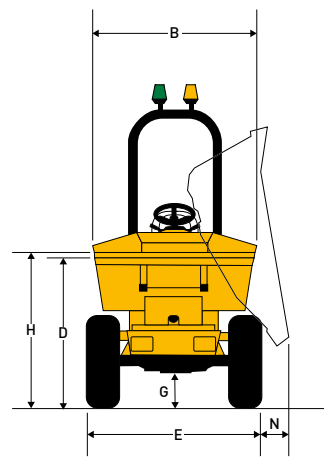
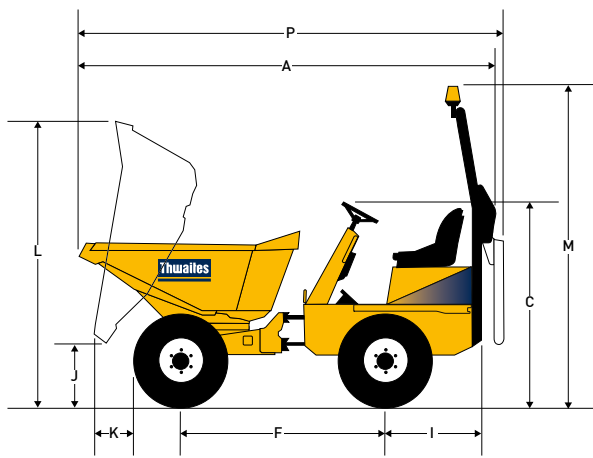

A	3726	N	189
B	1471	P	3891
C	1926		
D	1356		
E	1488		
F	1850		
G	282		
H	1416		
I	1042		
J	728		
K	475		
L	2671		
M	3053		

Weight	Unladen	2150 kg
	Shipping	2058 kg

Capacities	Max safe load	2300 kg
	Heaped	1205 litres
	Struck	875 litres
	Water	770 litres

Engine

- › Yanmar 3TNV88-BWWA, water-cooled, 3-cylinder water cooled direct-injection diesel
- › Power 18.1 kW/24.3 bhp at 2000 rpm
- › Torque 107 Nm (78.9 lbf ft)

Noise Levels

- › Operator's ear 84 LpA / airborne level 101 LwA

Transmission

- › Hydrostatic with high/low speed range, column mounted directional control lever and inching facility

Speeds	Forward and Reverse	
	Low	0–5.5 km/h (3.4 mph)
	High	0–15.0 km/h (9.3 mph)

Brakes and Axles

- › Totally enclosed multiplate oil-immersed discs mounted on rear axle & auto wear adjustment
- › Hand operated parking brake (SAHR)

Kinglink Chassis

- › Constructed from folded steel plate, with three point Kinglink giving articulation and oscillation for better stability, traction and safety on site

Skip

- › Hydraulically operated, 6 mm steel plate all round
- › Skip mouth & sides reinforced with box sections
- › Power Swivel skip enables a 180° rotation

Seating & Controls

- › Adjustable suspension seat with high-vis seat belt
- › LED warning lights for all critical functions

Service Access

- › Lockable engine cover for ground level service points
- › Diesel and hydraulic tanks positioned low permitting access to the filler caps

Electrics

- › Wiring harness contained within conduits and all electrical components water resistant to IP65/67 standards.

Steering and Hydraulics

- › Hydraulic power steering
- › Return line filtration for all services
- › Hydraulic test point fitted as standard

Tank Capacities	Fuel	24.5 litres
	Hydraulic	25.0 litres

Turning Circle	7.5m
-----------------------	------

Standard Equipment

- › Full LED road lighting incl. DRL (Daylight Running Lights)
- › LED beacons
- › Towing bracket
- › Reverse alarm

Optional Equipment

- › Road mirrors
- › Wheel nut indicator
- › Sand tyres

Thwaites

Thwaites Ltd, Leamington Spa,
Warwickshire, CV32 7NQ, England
Tel +44 (0)1926 422471

www.thwaitesdumpers.co.uk



Images are representative, but specific details or equipment may vary by country. We reserve the right to change any and all specifications without prior notice. 01/2022